

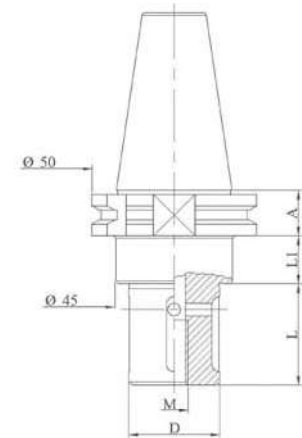

GRINDING WHEEL HOLDER

Code	A	D	L	L1
MVDIN310	19,1	12	20	15,9
MVDIN311	19,1	22	20	15,9
MVDIN322	19,1	22	34	15,9
MVDIN312	19,1	22	39	15,9
MVDIN323	19,1	22	47	15,9
MVDIN313	19,1	22	80	15,9
MVDIN314	19,1	35	20	15,9
MVDIN324	19,1	35	34	15,9
MVDIN315	19,1	35	39	15,9
MVDIN325	19,1	35	47	15,9
MVDIN316	19,1	35	80	15,9



LOCKING KIT

Kit made up of 2 spacer rings, 1 locking washer, 1 stainless steel or zinc-coated locking screw.

Code	d	D	E	M	S
M100	12	30	30	6	2
M200	22	60	45	10	3
M210	35	60	45	12	3

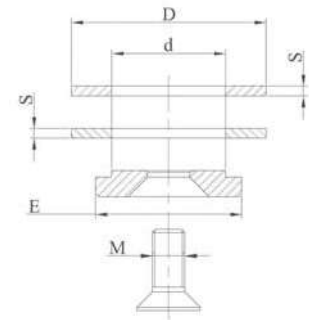

Special tool holders are made on request

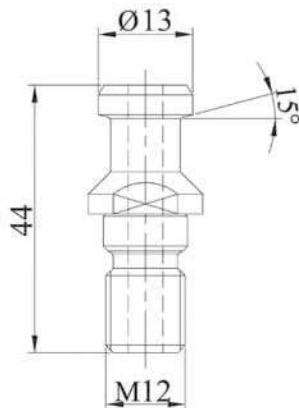

PULL STUD

Code	Type
MVDIN300	M12 angle 15°

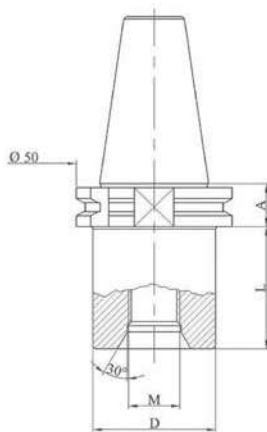

DRILL POINT HOLDER

Code	A	M	D	L
MVDIN301	19,1	1/2"	40	35
MVDIN302	19,1	1/2"	40	50
MVDIN306	19,1	M30	40	35



ER COLLET CHUCK HOLDER

Code	A	Collet type	D	L
MVDIN330N	19,1	ER25	42	53,4
MVDIN331N	19,1	ER32	50	53,4

For ER collets see page 77
 For wrenches see page 75
 For ring nuts see page 75



Special tool holders are made on request