

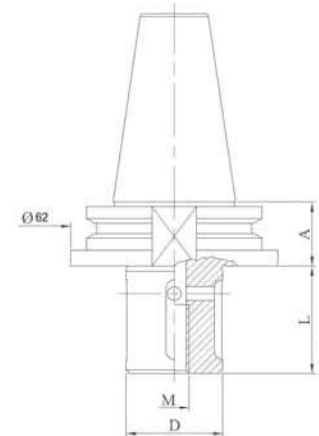

GRINDING WHEEL HOLDER

Code	A	D	L
MVIN309	25	12	20
MVIN310	25	13	34
MVIN311	25	22	20
MVIN322	25	22	34
MVIN312	25	22	39
MVIN323	25	22	47
MVIN313	25	22	80
MVIN313-B	25	22	90
MVIN324	25	35	34



LOCKING KIT

Kit made up of 2 spacer rings, 1 locking washer, 1 stainless steel or zinc-coated locking screw.

Code	d	D	E	M	S
M100	12	30	30	6	2
M200	22	60	45	10	3
M210	35	60	45	12	3

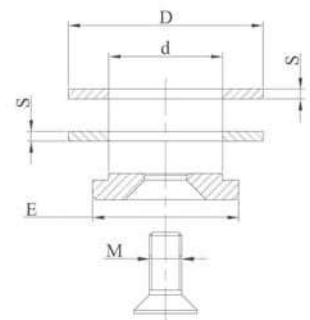

Special tool holders are made on request

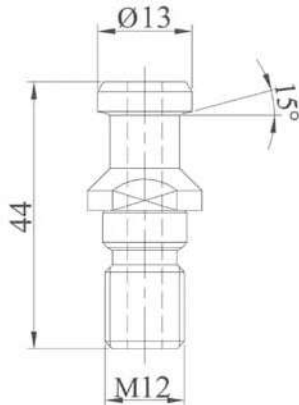

PULL STUD

Code	Type
MVDIN300	INTREMAC

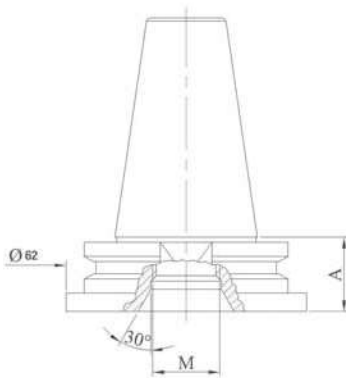

DRILL POINT HOLDER

Code	A	M
MVIN301	25	1/2"
MVIN306	25	M30

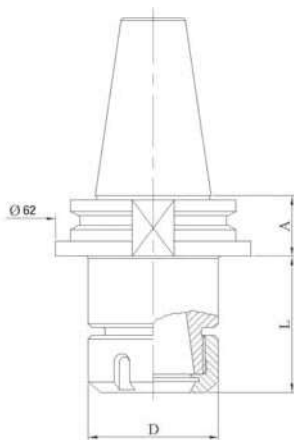

ER COLLET CHUCK HOLDER

Code	A	Collet type	D	L
MVIN330	25	ER25	42	52,5
MVIN331	25	ER32	50	52,5

For ER collets see page 77
 For wrenches see page 75
 For ring nuts see page 75



Special tool holders are made on request