

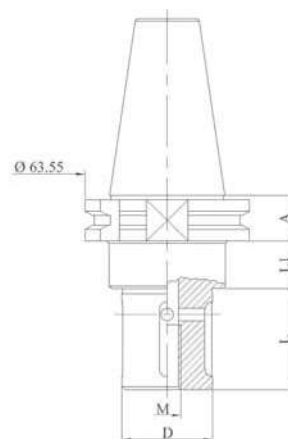

GRINDING WHEEL HOLDER

Code	A	D	L	L1
MVDIN411	19,1	22	20	15,9
MVDIN422	19,1	22	34	15,9
MVDIN412	19,1	22	39	15,9
MVDIN423	19,1	22	47	15,9
MVDIN413	19,1	22	80	15,9
MVDIN414	19,1	35	20	15,9
MVDIN424	19,1	35	34	15,9
MVDIN415	19,1	35	39	15,9
MVDIN425	19,1	35	47	15,9
MVDIN416	19,1	35	80	15,9
MVDIN417	19,1	45	100	15,9



LOCKING KIT

Kit made up of 2 spacer rings, 1 locking washer, 1 stainless steel or zinc-coated locking screw.

Code	d	D	E	M	S
M200	22	60	45	10	3
M210	35	65	45	12	3
M220	45	98	78	M16	3

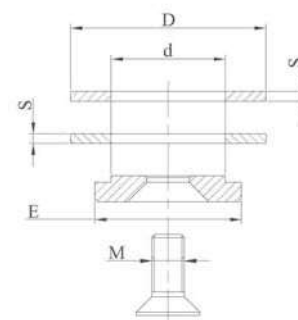

GRINDING WHEEL HOLDER

Code	A	D	L1
MVDIN421C	19,1	50	35
MVDIN426L	19,1	50	75

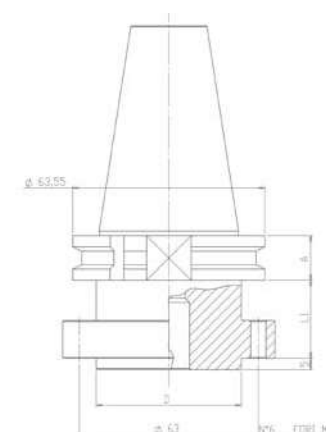

LOCKING KIT

Code	M	L
M230	n° 6 screws	35

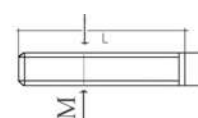

Special tool holders are made on request

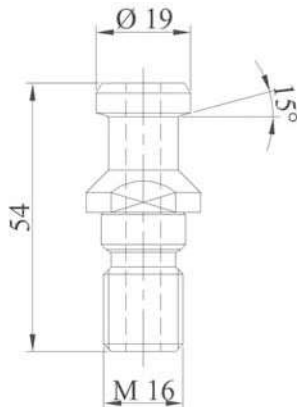

PULL STUD

Code	Type
MVDIN900	M16 angle 15°

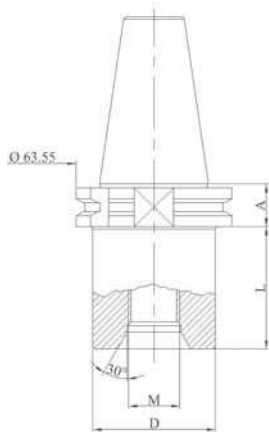

DRILL POINT HOLDER

Code	A	M	D	L1
MVDIN401	19,1	1/2"	-	0
MVDIN402	19,1	1/2"	50	100
MVDIN403	19,1	1/2"	50	150
MVDIN406	19,1	M30	50	50

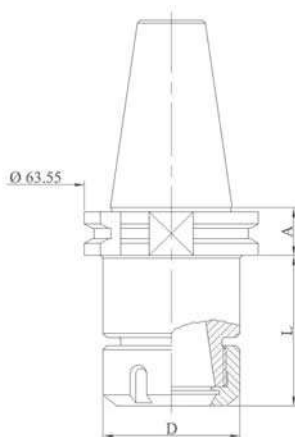

ER COLLET CHUCK HOLDER

Code	A	Collet type	D	L
MVDIN431	19,1	ER32	50	53,4
MVDIN432	19,1	ER40	63	57,4

For ER collets see page 77
 For wrenches see page 75
 For ring nuts see page 75

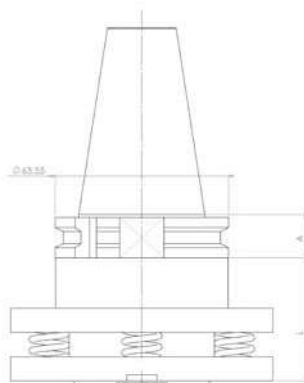

SPRING LOADED ADAPTER

Code	A	L
MVDIN440	19,1	40

Special tool holders are made on request