

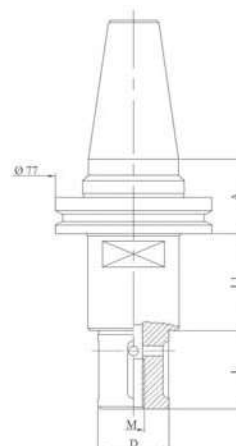

GRINDING WHEEL HOLDER

Code	A	D	L	L1
MVBR1110T	36,6	22	20	50
MVBR1220T	36,6	22	34	50
MVBR1120T	36,6	22	39	50
MVBR1230T	36,6	22	47	50
MVBR1130T	36,6	22	80	50
MVBR1140T	36,6	35	20	50
MVBR1240T	36,6	35	34	50
MVBR1150T	36,6	35	39	50
MVBR1250T	36,6	35	47	50
MVBR1160T	36,6	35	80	50
MVBR1170T	36,6	45	45	50



LOCKING KIT

Kit made up of 2 spacer rings, 1 locking washer, 1 stainless steel or zinc-coated locking screw.



Code	d	D	E	M	S
M200	22	60	45	10	3
M210	35	65	45	12	3
M220	45	98	78	M16	3

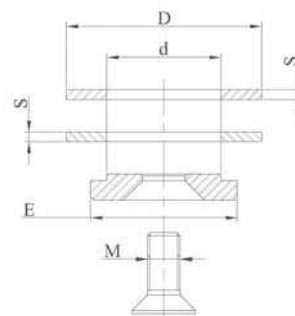

GRINDING WHEEL HOLDER

Code	A	D	L1
MVBR121COT	36,6	50	25
MVBR126LOT	36,6	50	70

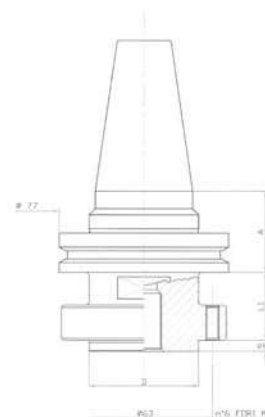

LOCKING KIT

Code	M	L
M230	n° 6 screws	35

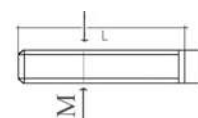

Special tool holders are made on request

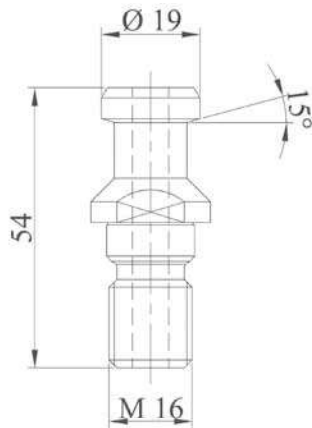

PULL STUD

Code	Type
MVBR900	M16 angle 15°

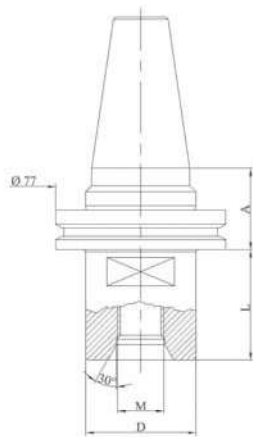

DRILL POINT HOLDER

Code	A	M	D	L
MVBR1010T	36,6	1/2"	45	45
MVBR1060T	36,6	M30	45	45

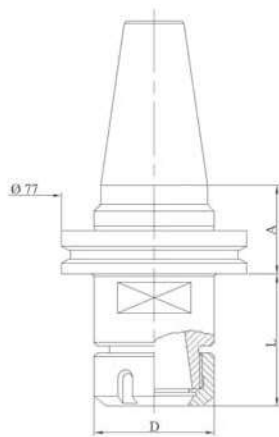

ER COLLET CHUCK HOLDER

Code	A	Collet type	D	L
MVBR1310T	36,6	ER32	50	42,5
MVBR1320T	36,6	ER40	63	46,5

For ER collets see page 77
 For wrenches see page 75
 For ring nuts see page 75

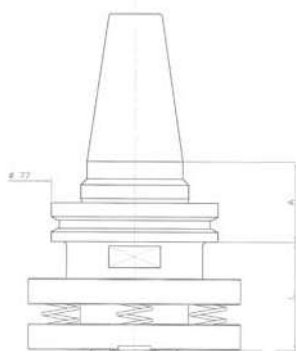

SPRING LOADED ADAPTER

Code	A	L
MVBR1400T	36,6	40

Special tool holders are made on request