

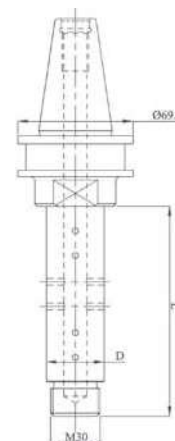

GRINDING WHEEL HOLDER

Code	D	L
MVAG122	22	34
MVAG112	22	39
MVAG123	22	47
MVAG113	22	80
MVAG124	35	34
MVAG115	35	39
MVAG125	35	47
MVAG118	35	124
MVAG116	35	80



LOCKING KIT

Kit made up of 2 spacer rings, 1 locking washer, 1 stainless steel or zinc-coated locking screw.

Code	d	D	E	M	S
M200	22	60	45	10	3
M210	35	60	45	12	3

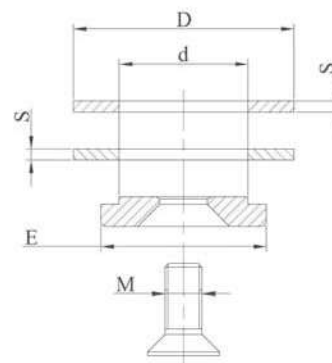

GRINDING WHEEL HOLDER

Code	d	D	L
MVAG1127	50	79	30
MVAG1128	50	79	100

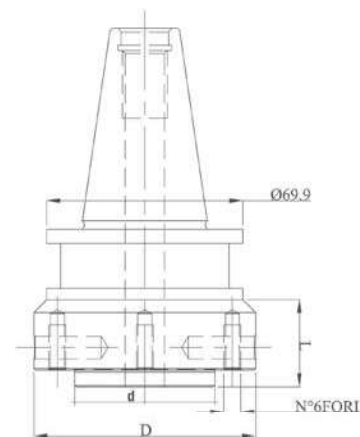

LOCKING KIT

Code	M	L
M230	n° 6 screws	35

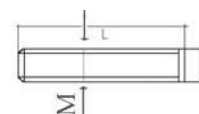

Special tool holders are made on request

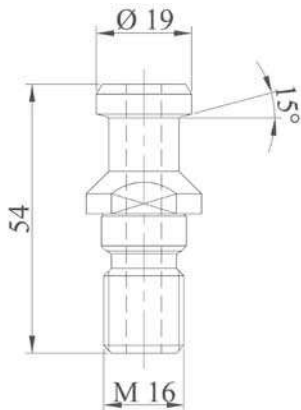

PULL STUD

Code	Type
MVBA900	M16 angle 15°

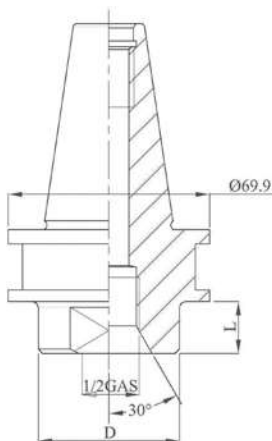

DRILL POINT HOLDER

Code	M	D	L
MVAG101	1/2"	49	18
MVAG102	1/2"	49	50
MVAG103	1/2"	49	80
MVAG104	1/2"	49	120
MVAG106	M30	49	18

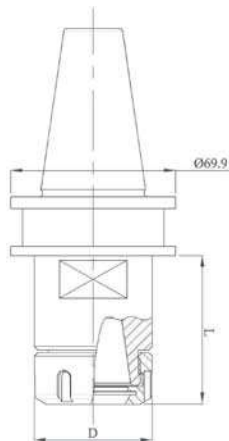

ER COLLET CHUCK HOLDER

Code	Collet type	D	L
MVAG131	ER32	50	53,4
MVAG132	ER40	63	57,4

For ER collets see page 77
 For wrenches see page 75
 For ring nuts see page 75

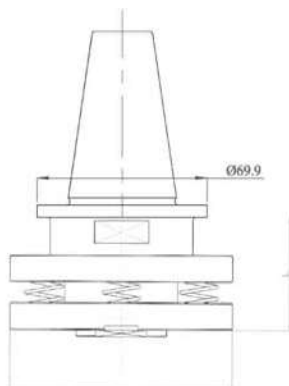

SPRING LOADED ADAPTER

Code	L
MVAG140	50

Special tool holders are made on request