

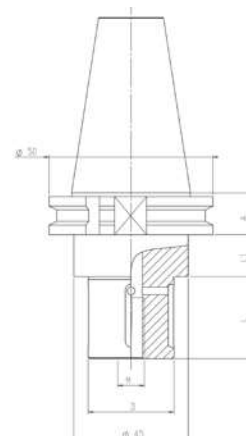

GRINDING WHEEL HOLDER

Code	A	D	L1	L
MVOM411	19,1	22	15,9	20
MVOM422	19,1	22	15,9	34
MVOM412	19,1	22	15,9	39
MVOM423	19,1	22	15,9	47
MVOM413	19,1	22	15,9	80
MVOM414	19,1	35	15,9	20
MVOM424	19,1	35	15,9	34
MVOM415	19,1	35	15,9	39
MVOM425	19,1	35	15,9	47
MVOM416	19,1	35	15,9	80



LOCKING KIT

Kit made up of 2 spacer rings, 1 locking washer, 1 stainless steel or zinc-coated locking screw.

Code	d	D	M	S
M200	22	60	10	3
M210	35	60	12	3

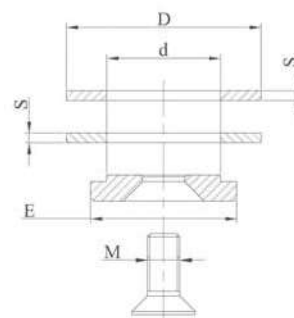

GRINDING WHEEL HOLDER

Code	A	D	L1
MVOM421C	19,1	50	35
MVOM426L	19,1	50	75

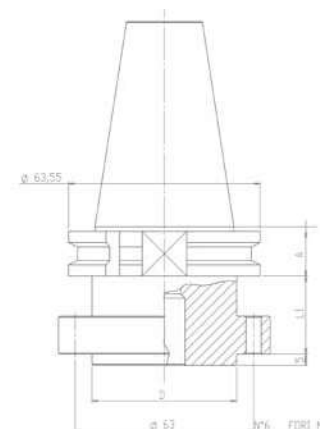

LOCKING KIT

Code	M	L
M230	n° 6 screws	35

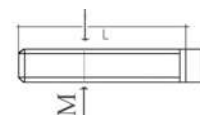

Special tool holders are made on request

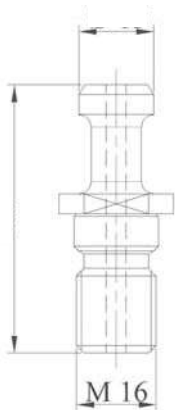

PULL STUD

Code	Type
MVOM900	M16
MVVE900	Angle 45°

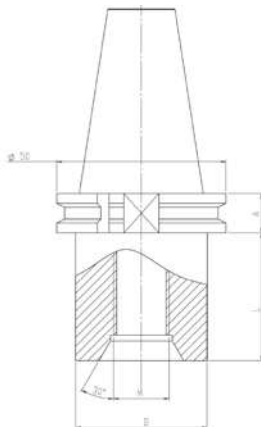

DRILL POINT HOLDER

Code	A	M	L
MVOM401	19,1	1/2"	20
MVOM402	19,1	1/2"	60
MVOM403	19,1	1/2"	100
MVOM404	19,1	1/2"	150
MVOM406	19,1	M30	50

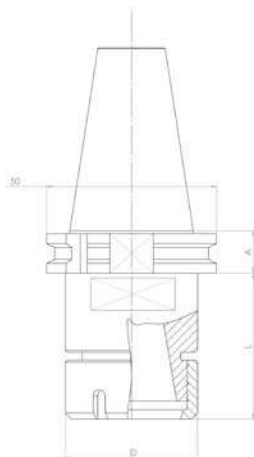

ER COLLET CHUCK HOLDER

Code	A	Collet type	L
MVOM431	19,1	ER32	72,5
MVOM432	19,1	ER40	72,5

For ER collets see page 77
 For wrenches see page 75
 For ring nuts see page 75

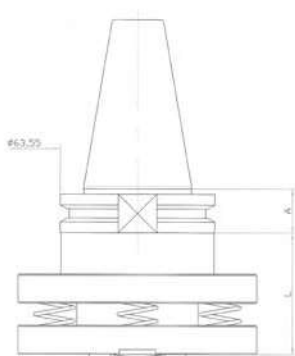

SPRING LOADED ADAPTER

Code	A	L
MVOM140	19,1	40

Special tool holders are made on request